

CREON

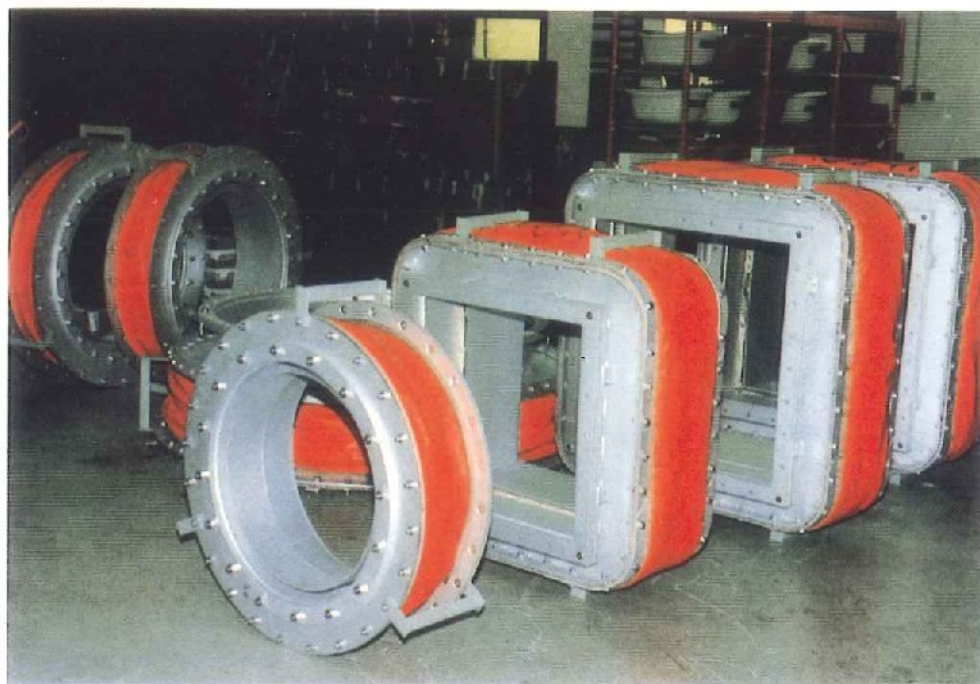

CREON N.V. was founded in 1984, with the aim of innovative problem solving in the young field of asbestos free fabric expansion joints, and in particular to manufacture to plant-specific requirements.

The many years experience of senior staff in plant construction along with the knowledge of technical fabrics and their applications gave a creative team that very soon acquired a good market name.

The continually increasing volume of orders and the constant product development as well as the increase in range of products led to the acquisition of a much larger production facility. This also allowed the combined manufacture of steel parts and expansion joints which met customer needs for complete unit deliveries.

A further enlargement in 1991 now allows PVC expansion joints to be produced in »state of the art« facilities.

What are Soft Material Expansion Joints?

They are highly flexible connections installed in pipe- and ductwork as well as industrial apparatuses to compensate for expansion, resulting from heat or misalignments as well as vibrations as a result from mechanical or acoustical movements. As a result of their flexibility fabric expansion joints can take axial, lateral and torsion movements or even angle motions.

CREON expansion joints are manufactured from high grade synthetic materials, elastomers and asbestosfree fabrics.

Soft material expansion joints are mainly employed for gaseous media, i. e. air or clean gas, or gas containing aggressive and abrasive as well as liquid matter. There is a wide variety of

materials available subject to the many of design criteria and application requirements.

The increasing requirements on soft material expansion joints demand a continuous product development. Skilled combination of flexible joints with steelparts provides solutions to critical tasks.

Data for soft material expansion joints in this leaflet are only meant as a guidance, since development of materials and manufacturing process must be considered. We reserve the right for technical improvements. We offer our assistance on design and projecting of soft material expansion joints.

Please feel free to contact our technical staff.

Quality assurance

CREON's quality assurance system keeps abreast with the demand for high grade materials and quality of workmanship of the industry. The quality control system covers raw materials, manufacturing and finished product as well as shipment packaging.

– All raw materials are subject to incoming goods control

- Quality control systems ensure the high grade manufacturing standard of CREON
- All expansion joints are produced with templets
- All finished products are subject to final quality control
- Quality control can request corrective actions or refuse shipment of the product
- The quality assurance manager reports directly to the M. D.

PEKOMP asbestosfree expansion joints are employed in the whole of Industry, i. e.:

General apparatus construction

Chemical Industry

DENOX units

Rotary furnace/Kiln plants

Dust extraction plants

Gas cleaning and -drying units

Gas turbine plants

Gas washing equipment

Metallurgical and smelter Industry

Industrial furnace constructions

Nuclear power plants

Air-conditioning units

Power plants, boiler- or diesel-powered plants

Coating units

Venting units

Waste firing plants

Paper Industry

Petrochemical Industry

Refineries

Ship's power plants/machinery and Off-shore equipment

Stack construction

Thermal treatment units

Drying equipment

Desulfurizing plants

Ventilator- and blower units

Packaging Industry

Weighing equipment

Heat technology equipment

Cement Industry

Design Criteria

To correctly layout expansion joints the following detailed criteria are required.
 In some cases an analysis of the media will be required. The accuracy of these details is important, as inaccurate or missing details could lead to the destruction of the expansion joint and invalidate the guarantee.
 The most important criteria in selecting a suitable expansion joint are:

1 Media	Details as accurate as possible
2 Temperature	Service temperature, possible temperature in case of faults, design temperature
3 Pressure	Maximum possible service pressure positive/negative
4 Direction and velocity of flow	Maximum velocity of flow is required to asses need for baffle. The direction of flow is important when the medium contains particulate matter
5 Mechanical load	The movements which the expansion joint has to accomodate
6 Particulate matter	Type, size and amount in media, (abrasion)
7 Dew point and chemical influence	To confirm material suitability
8 External influence	Ambient temperature and other possible aggressive factors
9 Leak requirement rate	To lay out type of fastening and design of flange area.
10 Place of installation	Open air / in building, which part of plant, in special cases a sketch may be needed.

Our technical questionnaire on pages 24 and 25 helps answer specific questions.

Forms of Constructions

Construction form B1 (Tube/Tape form)

(only round available)

Temperature range: -60 to 450 °C

Pressure: up to 200 mbar

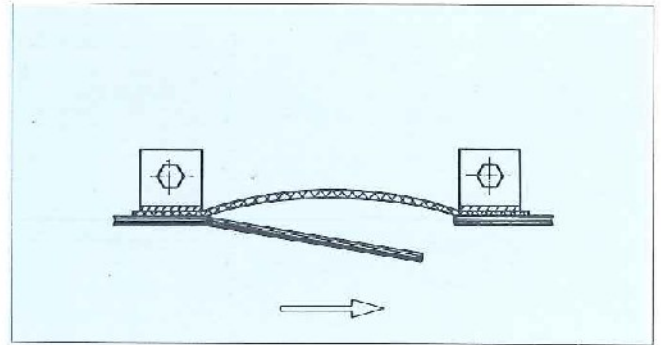

Construction form B2 (U-Shape round)

Construction form B3 (U-Shape square)

Temperature range: -60 to 600 °C

Pressure max.: pressure surge resistance

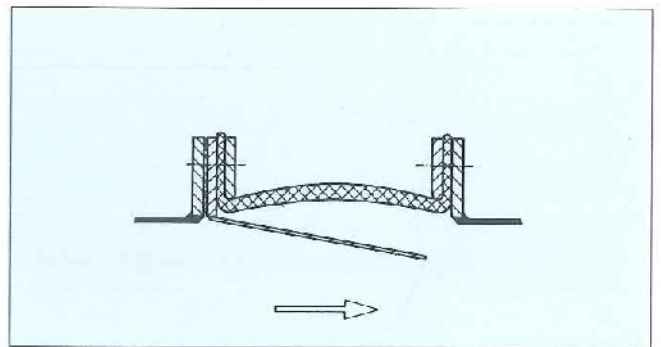

Construction form B4 (Tube form round)

Construction form B5 (Tape form square)

Temperature range: -60 to 1 200 °C

Pressure max.: pressure surge resistance

Above 600 °C a pre-insulation is necessary.
A baffle-plate must be installed when velocity exceeds 20 m/s or if particles are expected in the media.

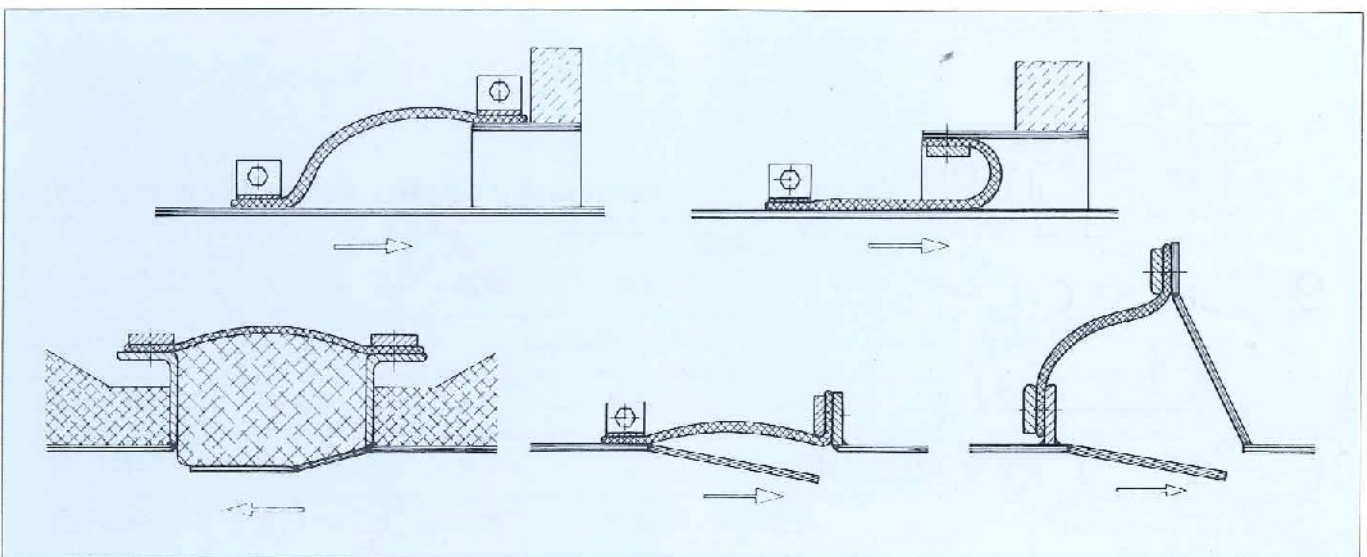
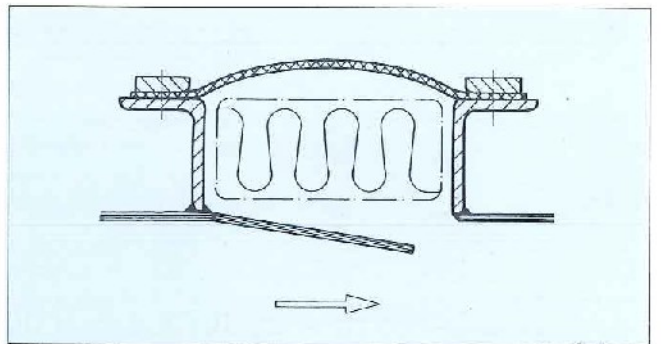

Special forms of construction with specially designed steel parts ensure safe solutions of critical applications.

Force of Displacement

The force of displacement for CREON expansion joints B1, B2 and B3 are negligible.

The ring areas, subject to construction of B4 and B5 and of some special construction forms together with the internal pressure, cause a force that must be taken into account when the pipe support is designed. This must be considered by the designing engineer.

Formula: Ring area \times pressure = force of displacement.

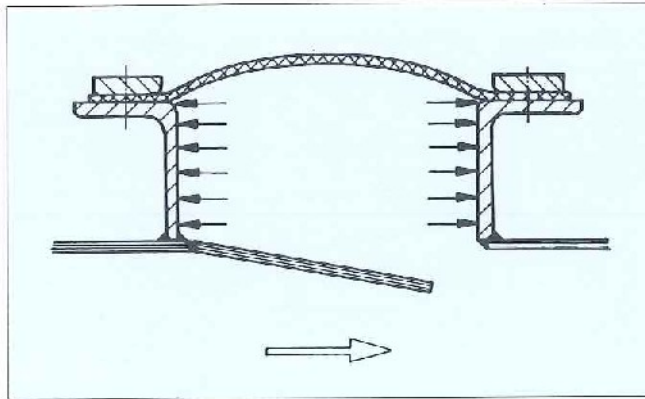

Expansion/Movements

The various movements are subject to:

- Rise of temperature from ambient-to operating temperature.
- Lay-out of piping system.
- Fixed points of piping and separation of same.

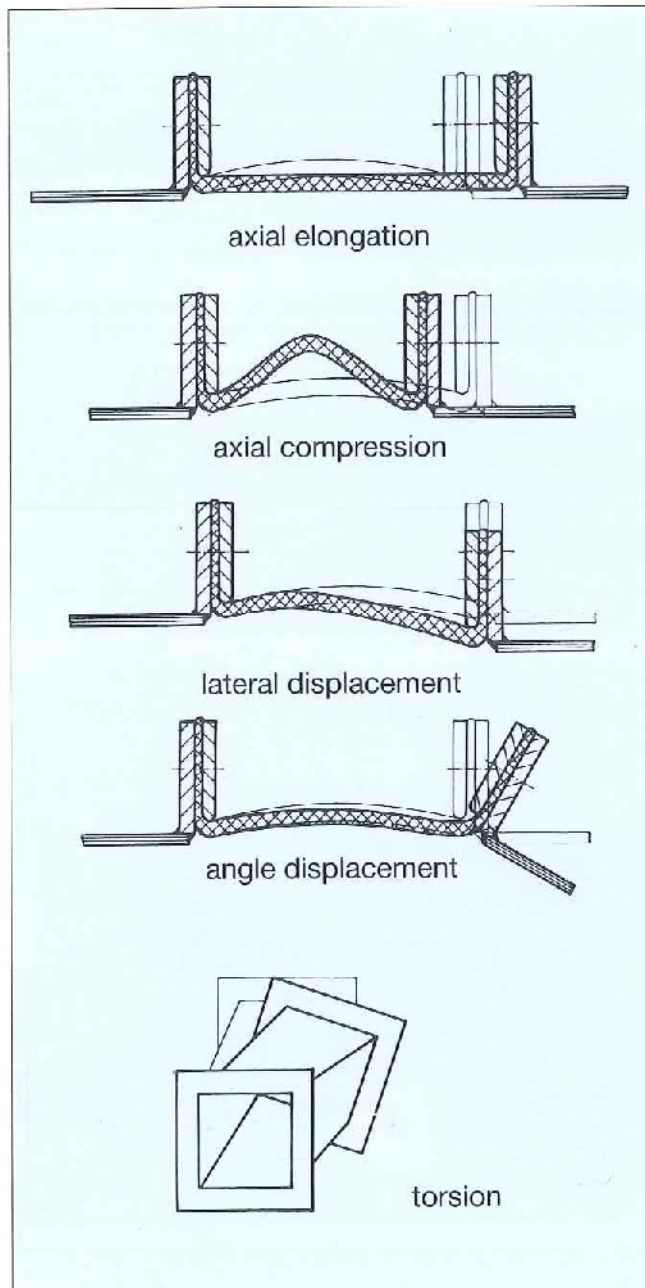

Pipe schematic to determine movements of expansion joints

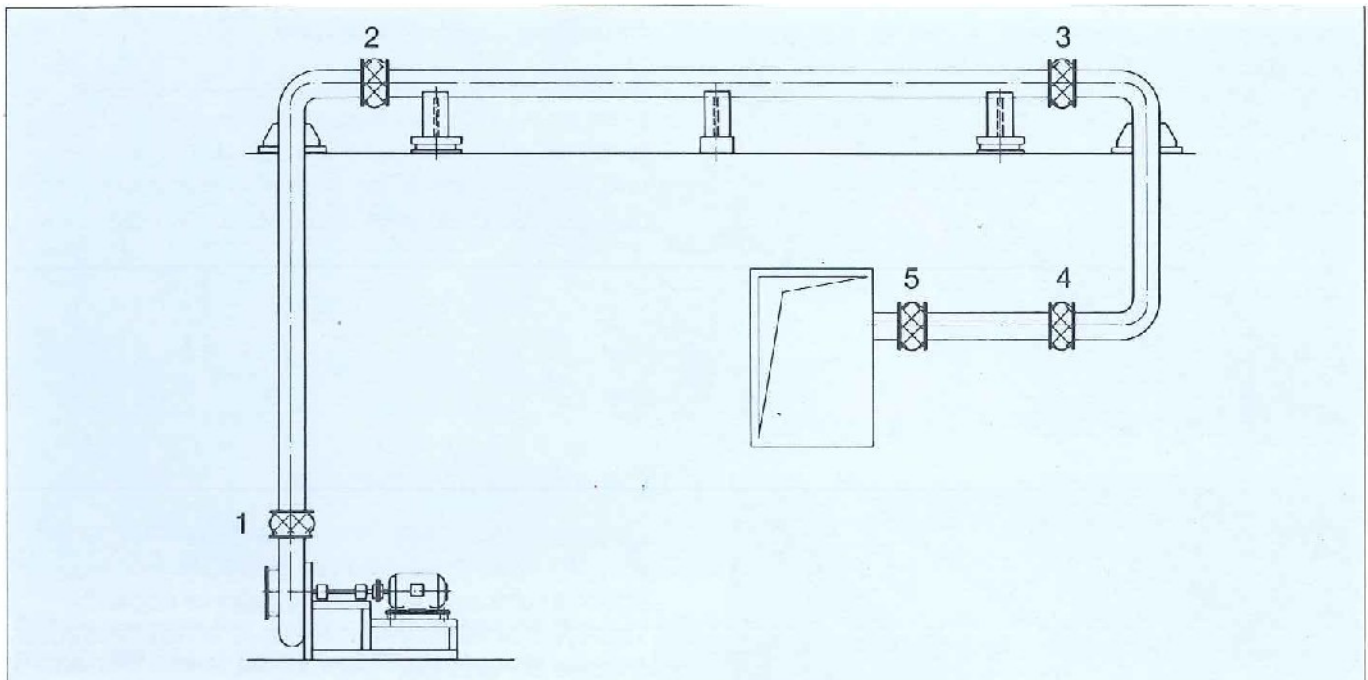

Expansion joint no.	Kind of expansion/movement
1	axial compression
2	axial compression and lateral expansion
3	axial compression and lateral expansion
4	axial compression and angle motions
5	angle motions

Alteration of pipe length with change of temperature is calculated using the formula:

$$\Delta L = L \times \alpha \times \Delta T, \text{ wherein}$$

ΔL = alteration of length in mm

L = length of pipe between fixed points in mm

α = coefficient of expansion in $\text{m/m} \times ^\circ\text{C} \times 10^{-5}$

ΔT = temperature difference in $^\circ\text{C}$

Coefficient of expansion α of some materials

Material	Temperature ($^\circ\text{C}$)						
	100	200	300	400	600	800	1 000
	Coefficient of expansion $\alpha = \text{m/m} \times ^\circ\text{C} \times 10^{-5}$						
Steel St 37-2	1.1	1.2	1.3	1.4	–	–	–
SS 1.4541	1.6	1.7	1.7	1.8	1.8	–	–
SS 1.4828	1.65	1.7	1.75	1.75	1.8	1.85	1.95

Values in accordance with DIN

CREON steel parts for installation of expansion joints

Clamping strap attachment

Installation with clamping straps can only be used on round tube shapes. The number of clamp joints on circumference is subject to diameter and temperature of the pipe. Clamping straps can only be used with construction shape B1.



Counter flange attachment

Counter flanges are manufactured with a round, smooth inner edge and are attached with countersunk screws with hexagonal socket. This type of attachment is found on construction shapes B2 and B3.



Attachment with clamp flanges

Drilled clamp flanges are applied where higher temperatures and pressures are foreseen for band shape expansion joints such as forms B4 and B5.

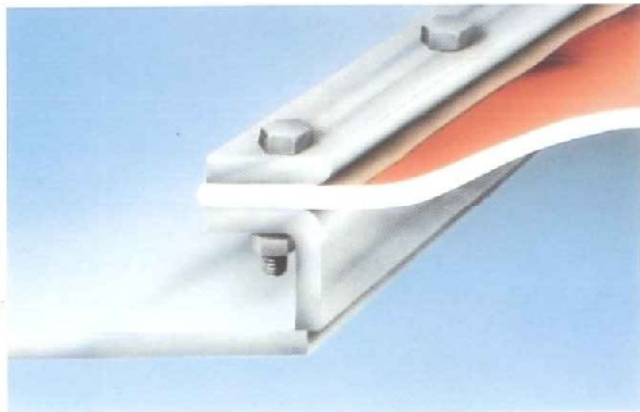

Attachment with clamp flange on corners

To ensure tightness, corners are rounded when B5 construction shape is used on square or rectangular ducts.

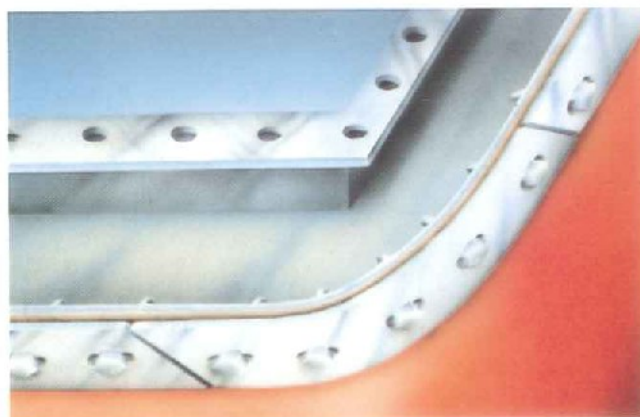

Assembly possibilities of expansion joints without holes punched for mounting except for shape B1.

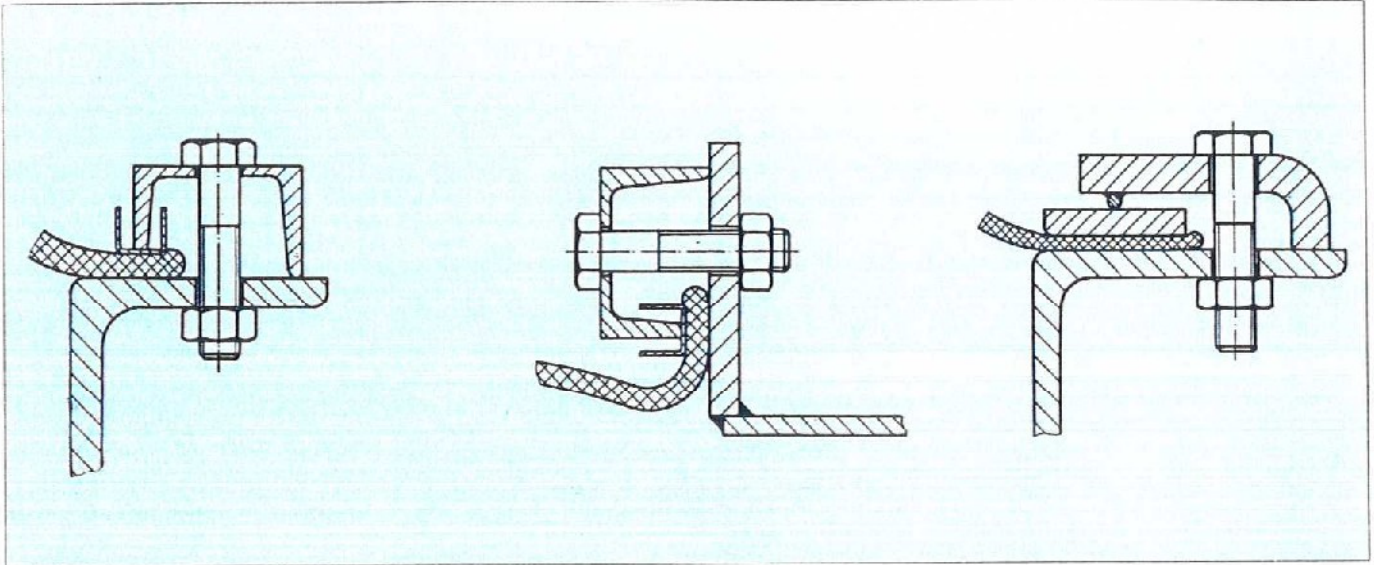

Other expansion joint equipment of the steel parts manufacturing

- Duct flanges
- Counter flanges
- Clamp flanges
- Baffles
- Floating baffle plates
- Complete units, ready for installation

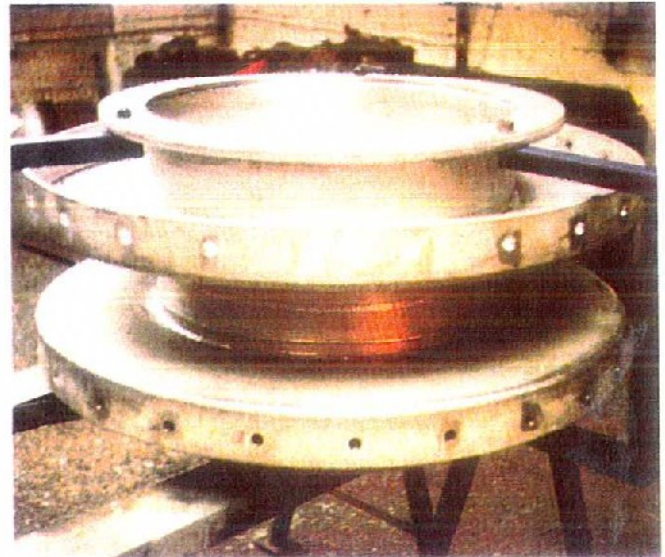
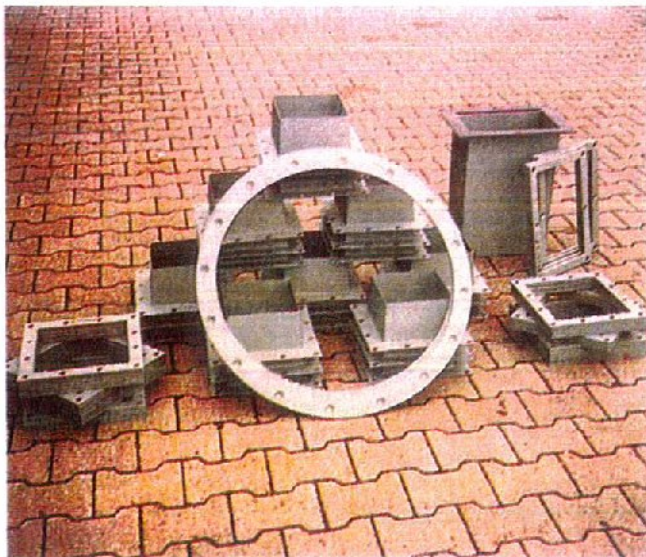
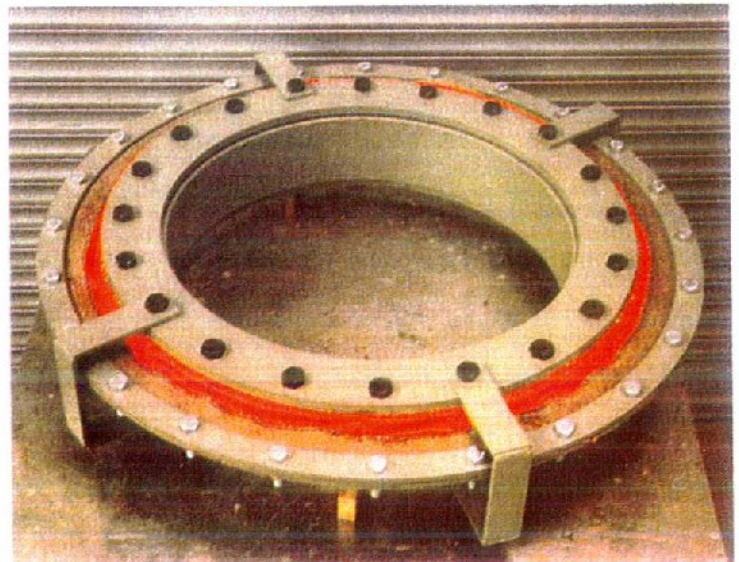

Insulation near Expansion Joints

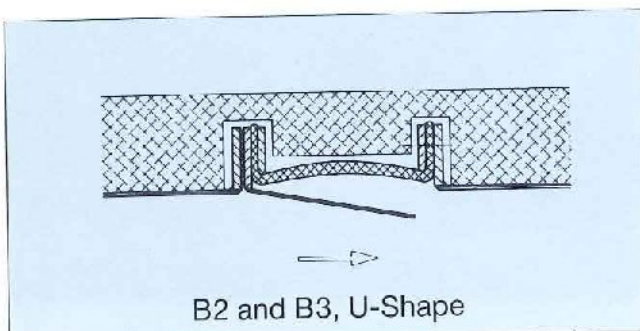
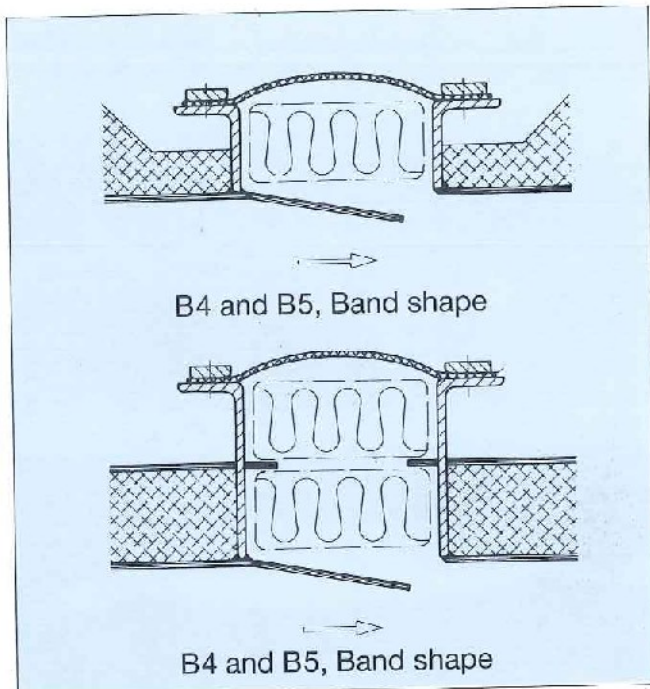
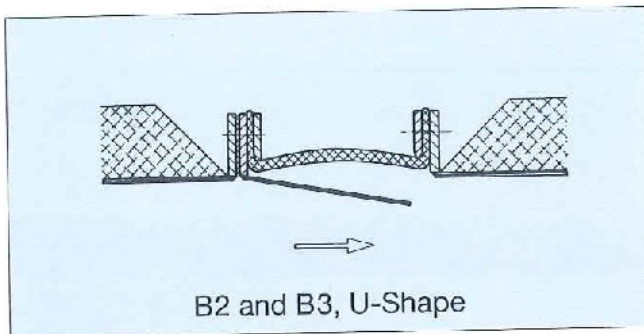
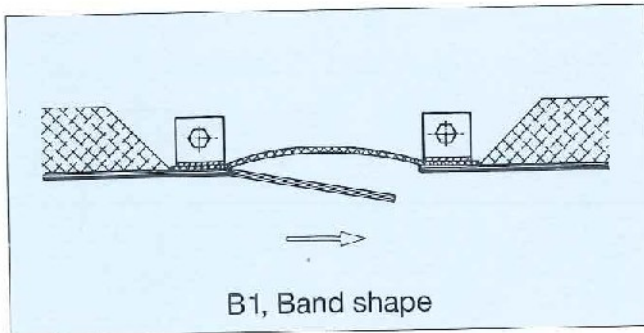

Outer insulation

Basically, do **not** insulate fabric expansion joints.

Outer insulation must be applied as shown on the sketches and in accordance with construction shape. Allow sufficient air circulation around the mounting area of the flex joint to ensure radiation of heat.

Inner insulation

Isolation package (Pre-insulation) is installed to protect the leakproof materials in expansion joints from heat.

CREON pre-insulations are constructed in such manner to ensure repositioning to original location after movements.

Caution

If outer insulation is required, CREON's agreement must be obtained.

Packaging and Transport

According to size of expansion joint, mode and time of transportation and expected storage time, the CREON Flex joints are differently packed. Packaging is meant to safeguard and protect the unit during transport and storage at the construction site.

Packaging can be executed from carton to sea-worthy packaging in wooden crates. It is ensured that handling can be made by crane or forklift truck.



Storage

Below listed recommendation should be observed:

- Store expansion joints indoors in a dry place. Do not remove from package.
- Remove unit only immediately prior to installation from package!
- Do not place loads on package. Protect against sparks and fire.
- Protect unit from being damaged by sharp articles or objects.
- Observe installation instructions.



Preparation for Installation

It is recommended to inspect the location for installation of the CREON fabric expansion joint, thereby examine the following:

- Are flanges straight and free from welding droplets?
- Are steel parts rounded and smooth in the installation area?
- Check dimensions of construction length.
- Are flanges parallel?
- Do the holes agree on all flanges and counter flanges?
- If steel parts are not delivered by CREON, check if those agree with CREON standard.



Installation

- CREON expansion joints must be removed from package only immediately prior to installation.

The installation can be handled as follows:

- By CREON personnel.
- Under guidance of a CREON's field engineer.
- With buyers personnel and in accordance with written instructions and final inspection by CREON representative.
- Finally, same as above but without final certification by CREON.

In the event of open bandform delivery that have to be closed on the construction site, instructions to do so are enclosed in the package together with a kit, containing the necessary tools and materials.

CREON assists the customer on best mode of installation. Consideration being given to site conditions and warranty.

Commissioning

After warm-up, check the flex joint and firm up bolts.



Peko-Gumm (PGU)

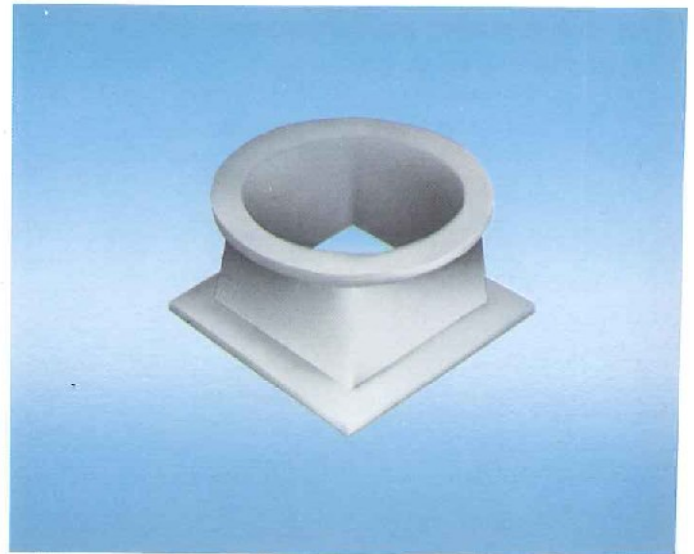
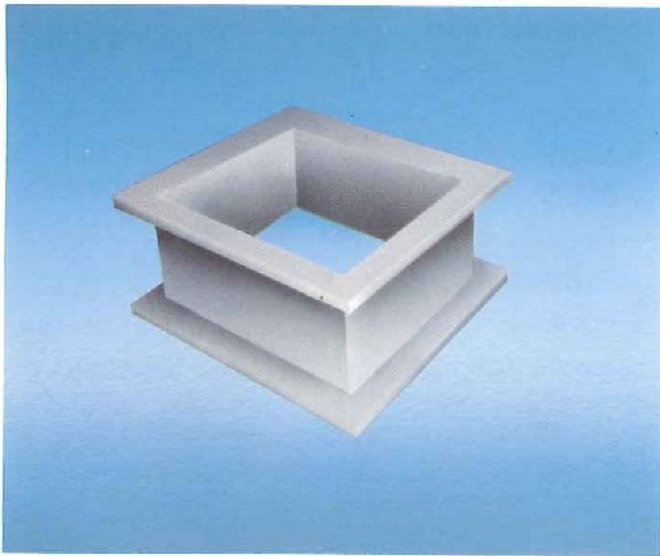

Peko-Gumm expansion joints
have been developed for:

Conveying equipment

Screening equipment

Food Industry

Ventilation system plants



The outstanding performances of rubber material e.g.:

- Flexibility
- Flexing work
- Impermeability
- Modulus of elasticity
- Interruption of structure borne noise
- Vibration absorption etc.

have been used by CREON

Materials like:

- Neoprene (CR)
- Natural rubber (NR)
- EPDM (EPDM)
- Butyl Rubber (IIR)
- Hypalon (CSM)
- Food quality rubber (NBR)

are manufactured in material thickness from 2-8 mm by CREON

Various shapes and constructions are manufactured to fulfil customers expectation and help to solve their problems.

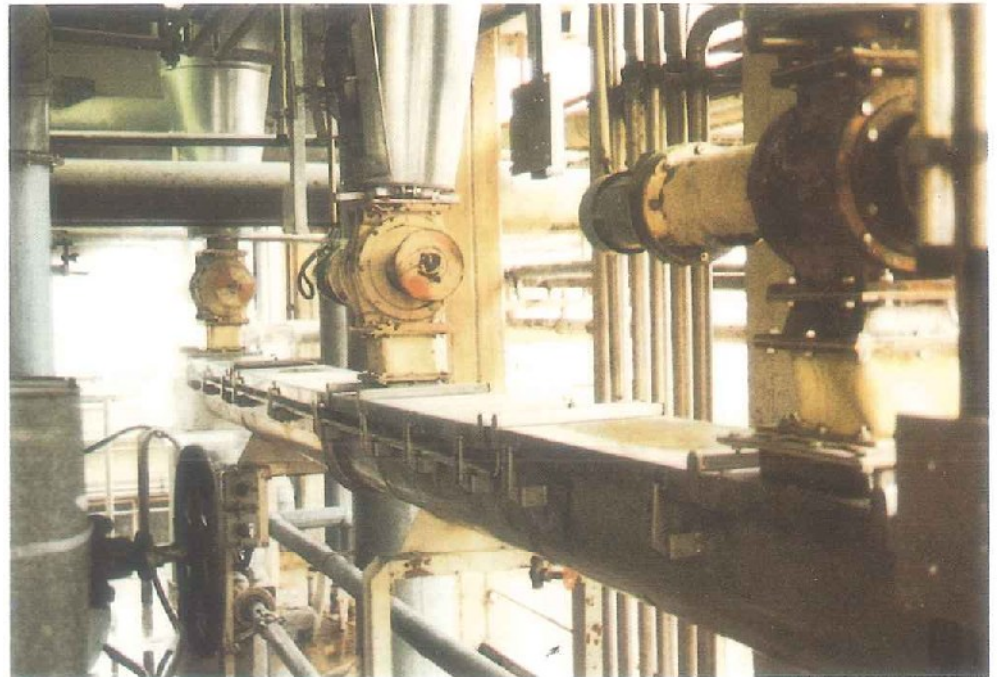

Material qualities as a function of temperature and pressure

Material	Temperature range	Pressure range
Neoprene	-30 to 100 °C	Maximum rated pressures are a function of material thickness and construction form/shape.
Natural rubber	-40 to 70 °C	
EPDM	-50 to 120 °C	
Butyl rubber	-30 to 120 °C	
Hypalon	-30 to 130 °C	
Food quality	-10 to 70 °C	

Peko-Flott (PFF)

The flex joint from the coil –
a fast solution.

There are two different types available:

PEKO-FLOTT BLACK, for air

PEKO-FLOTT BROWN, for flue gas

PEKO-FLOTT is made from the same high grade materials as the asbestosfree fabric expansion joints.

PEKO-FLOTT comes in packages containing instructions for connection and installation as well as materials to glue, connect and necessary tools.

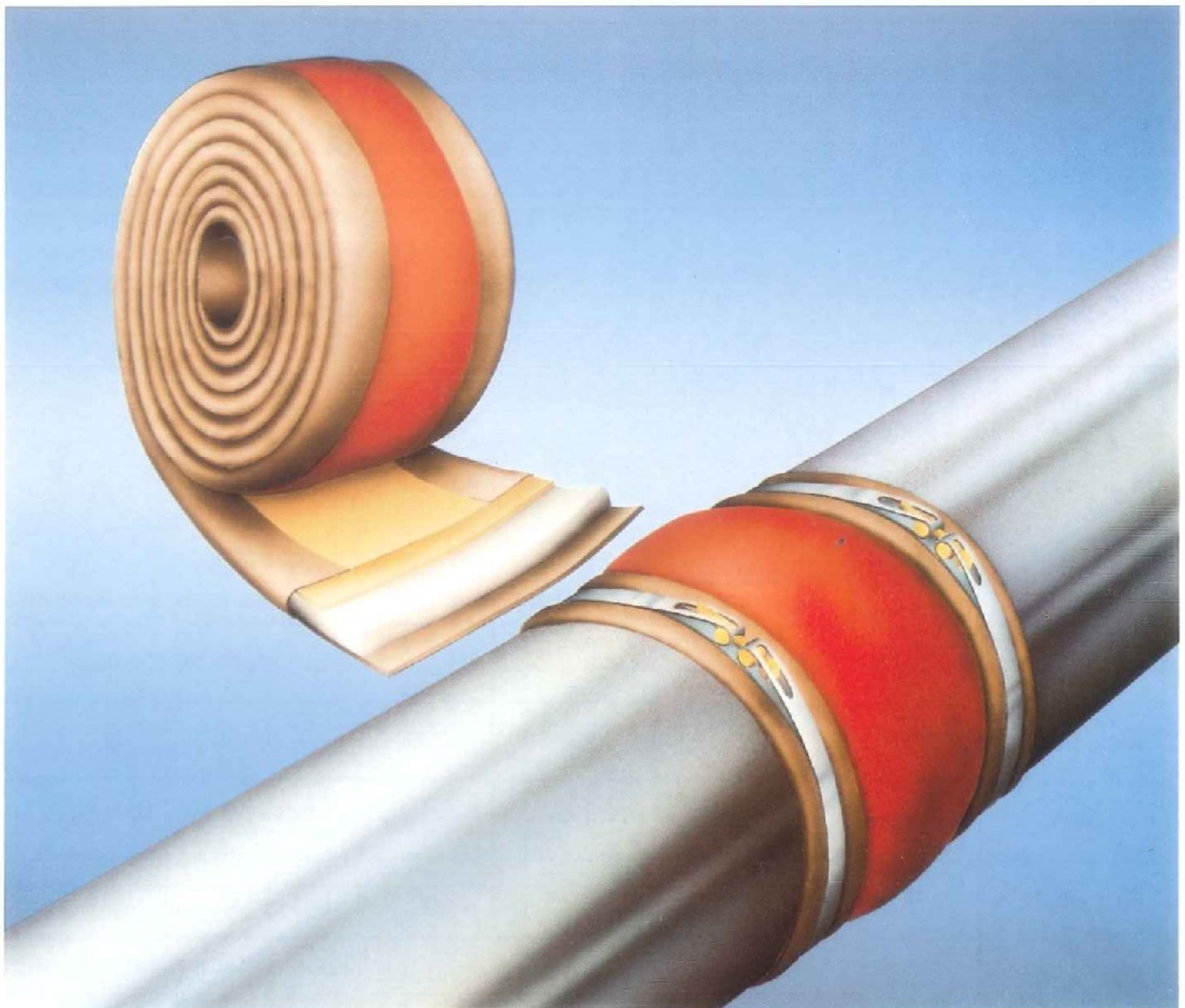
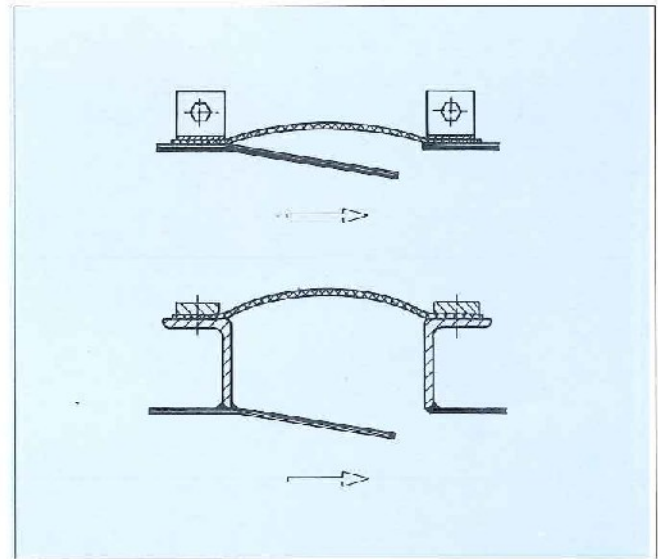



**Peko-Flott
black, for air**

Construction

- Glass fabric for re-enforcement of either flange or clamp strap and for lesser permeability.
- Silicon-coated glass fibre for protection against the environment.
- Glass felt for temperature reduction.
- Glass fabric for protection of the insulating material.



**Peko-Flott
brown, for flue gas**

Construction

The construction is as for Peko-Flott black. However there is PTFE-foil integrated between the silicon-coated protection ply and the glass felt as an acid barrier.

Max. temp.	Peko-Flott, black, for air only			Peko-Flott, brown, for flue gas		
	200 °C	300 °C	550 °C	200 °C	300 °C	550 °C
Type	PFF-020-KN	PFF-030-KN	PFF-055-KN	PFF-020-LN	PFF-030-LN	PFF-055-LN
Coil length	40 m	20 m	15 m	40 m	20 m	15 m
Coil width	200 – 335 – 500 mm					

Peko-Flex (PFE)

CREON manufactures single ply expansion joints, using a number of proven high grade materials. Type PFE is built in various shapes.

Peko-Flex single ply flex joints are especially suitable for construction forms B1, B2 and B3 and are well capable to cope with

- extreme axial and lateral movements
- vibration absorption
- misalignments

Peko-Flex single ply can be delivered with clamping straps (B1) or with counterflanges (construction shapes B2 and B3).

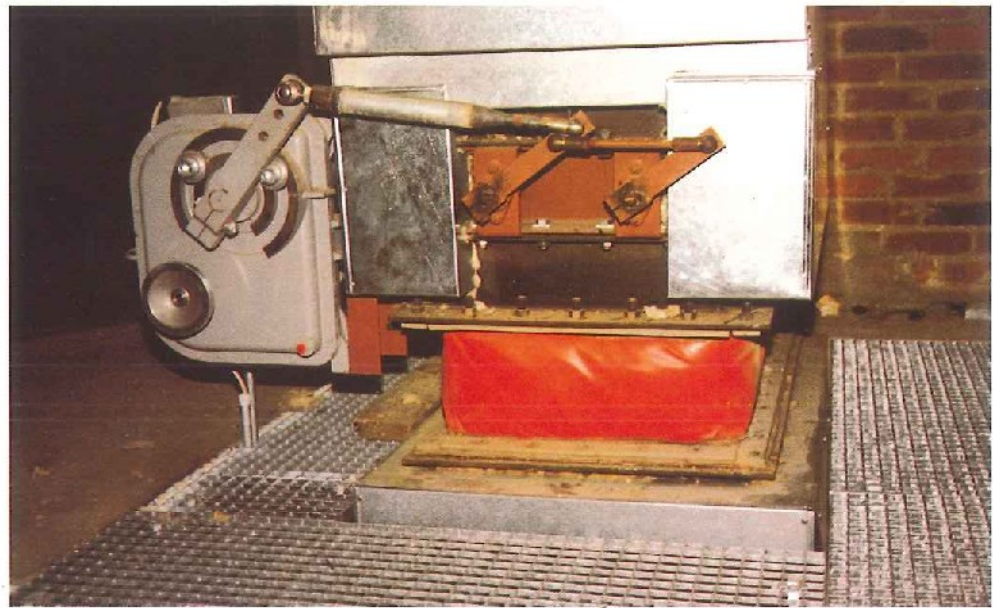
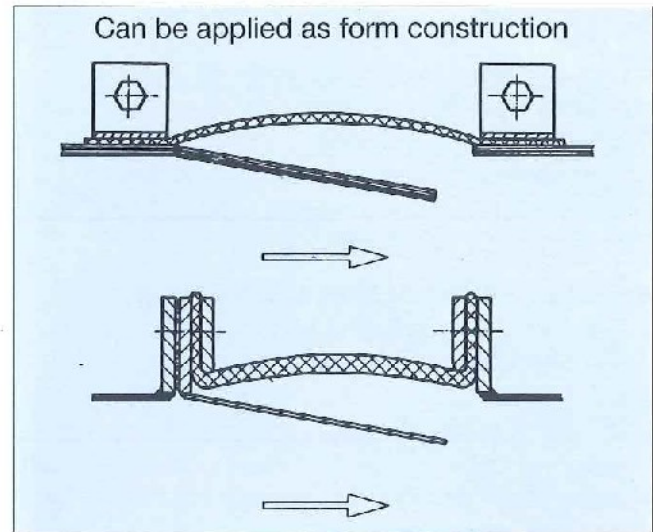

Material qualities as a function of temperature and pressure

Material	Temperature range	Pressure range
PVC-Polyester	-25 to 60 °C	up to 200 mbar
Butyl-Polyamid	-30 to 130 °C	
Hypalon-Polyester	-55 to 100 °C	
Al-coated glass fabric	-20 to 150 °C	
Silicon-coated glass fabric	-60 to 200 °C	
Double silicon-coated glass fabric	-60 to 200 °C	
Viton-coated glass fabric	-20 to 200 °C	

Peko-Flex (PFM)



Multiply expansion joints are capable to:

- take axial and lateral movements
- absorb vibrations
- cope with misalignments
- be installed in air supply duct work/piping or exhaust ducts/smoke-headers, subject to construction of the various plys.

Standard construction of a PFM type

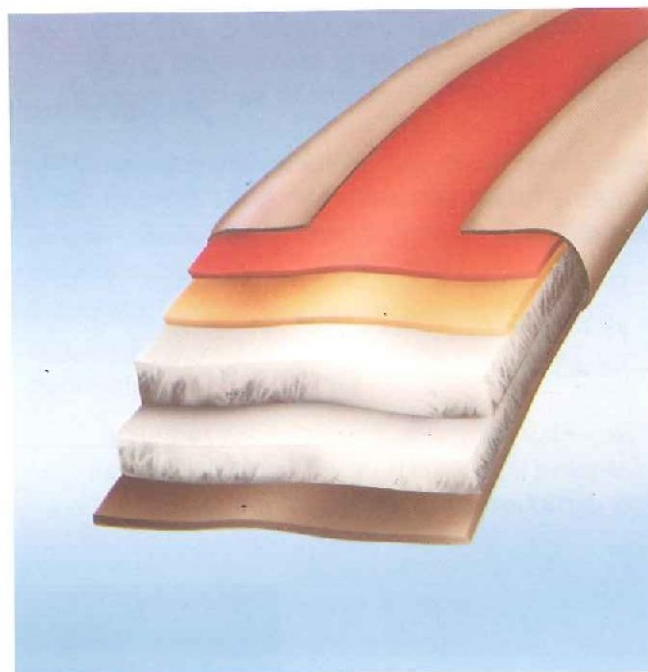
- Reinforcing glass fabric in flange area.
 - Silicon-coated glass fabric for ambient protection.
 - PTFE-foil (welded), as an acid barrier.
 - Glass- or ceramic fiber as temperature protection.
 - Superduty silica- or glass fabric to protect the insulation package.
 - Pre-insulation to protect the flex joint against temperatures above 600 °C.
- Construction and shape varies with temperatures, movements expected and construction form.

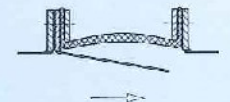

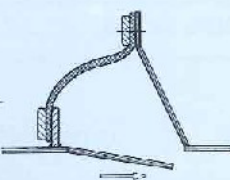
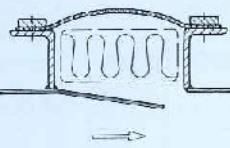
Construction form	Temperature range	Pressure range
 <p>B1</p>	-60 to 450 °C	up to 200 mbar
 <p>B2 + B3</p>  <p>B4 + B5</p>  <p>Special shaped</p>	-60 to 600 °C	up to 200 mbar, pressure surge resistance
 <p>B4 + B5</p>	-60 to 1 200 °C	up to 200 mbar, pressure surge resistance

Baffle plate

To ensure long service and for protection of the flex joint, baffle plates have to be installed if velocity of the gas exceeds 20 m/s or abrasive media is expected.

Peko-Flex (PFM)

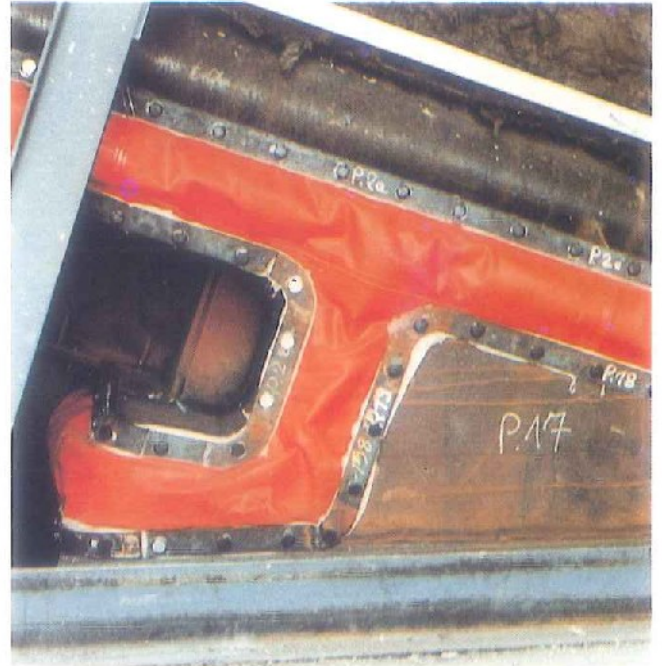

Peko-Kraft (PKR)





These multiply flex joints have a robust outer ply for better ambient protection. They are capable to:

- take axial and lateral movements
- absorb vibrations
- cope with misalignments
- be installed in air supply duct work/piping or exhaust ducts/smoke-headers, subject to construction of the various plies.

Peko-Kraft flex joints are built with a 4 mm thick rubber outer ply to protect the expansion joint against rough ambient and environment. They are used in steel- and iron industries, smelters, cement-industries, heavy- and mining industries.

Construction

- Reinforcing glass fabric in flange area.
- 4 mm rubber ply for heavy duty service.
- PTFE-Foil, welded, as an acid barrier or other chemical aggressive media.
- Glass- or ceramic fiber for temperature reduction.
- Superduty silica- or glass fabric to protect insulation.

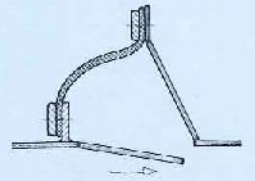
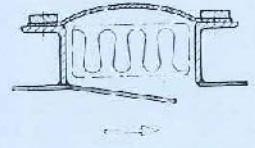
Construction form	Temperature range	Pressure range
 B2 + B3  B4 + B5  Special shaped	-30 to 200 °C	up to 200 mbar, pressure surge resistance
 B4 + B5	-30 to 450 °C	up to 200 mbar, pressure surge resistance

Baffle plate

To ensure long service and for protection of the flex joint, baffle plates have to be installed if velocity of the gas exceeds 20 m/s or abrasive media is expected.

Peko-Stahl (PST)

These multiply expansion joints are capable to:



- take axial and lateral movements
- absorb vibrations
- cope with misalignments
- be installed in air supply duct work/piping or exhaust ducts/smoke-headers, subject to their construction.

Peko-Stahl flex joints are constructed with a stainless steel wire mesh to stabilize the given shape. The form is thus maintained during duty.

Construction

- Reinforcing glass fabric in flange area.
- Silicon-coated glass fabric for ambient protection.
- PTFE-Foil, welded, as an acid barrier.
- Glass- or ceramic fiber for temperature reduction.
- Supperduty silica- or glass fabric to protect insulation.
- SS wire mesh for shaping and maintenance of shape.

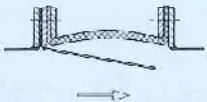

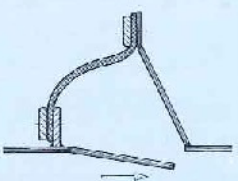
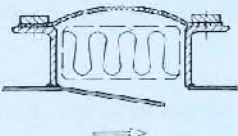
Construction form	Temperature range	Pressure range
 B1	-60 to 450 °C.	up to 200 mbar
 B2 + B3  B4 + B5  Special shape	-60 to 600 °C	up to 200 mbar, pressure surge resistance
 B4 + B5	-60 to 1 200 °C	up to 200 mbar, pressure surge resistance

Special Expansion Joints Peko-Sulforesist (PSR)

This type of expansion joint has been developed to give best possible protection against chemical media, e.g. for De-sulphurizing plants.

Example of construction

- PTFE-foil 0.4 mm thick for optimum protection against chemical aggression. Thermal resistant up to 220 °C.
- Glass fabric as support ply for the PTFE-foil. PTFE-foil 0.21 mm for increased protection.
- EPDM outer protection skin 2–3 mm thick against chemical environment and weathering.
- 2 mm Fluorine elastomer, profile sleeve to ensure high unpermeability using the swell property of Viton in the clamp flange area.

The Sulforesist flex joint is delivered virgin and with clamp device, thus lifetime is increased since the PTFE-foils are not punctured.

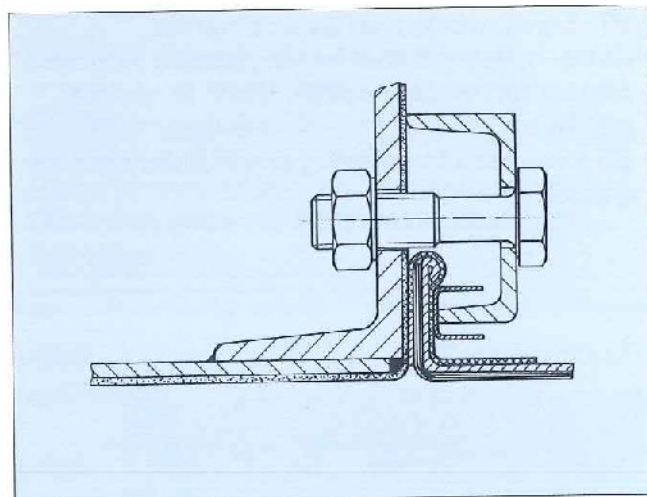
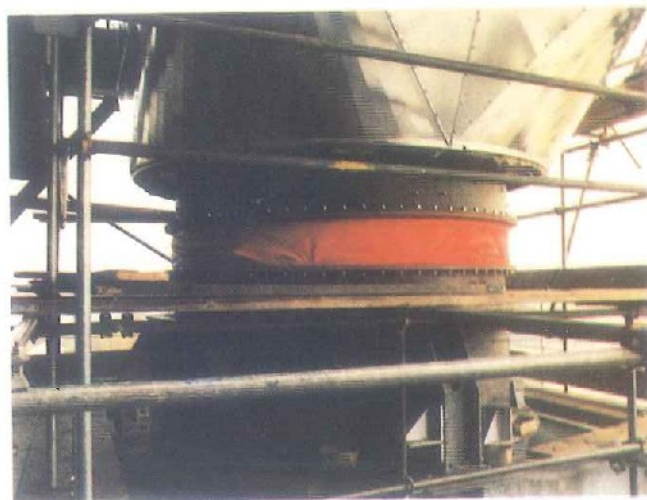

Assemblage

Rampant channel steel, circulated

Solid flange connection, even distribution of force, ensured frictional connection in the area of impermeability. Spring load of the channel compensates for heat expansion. No elongation of screws. Heat loss via steel parts is ensured thus the Fluorine-elastomer sleeve is less stressed.

Channel steel, circulated

Distributes pressure and evens surface pressure thus flowage of PTFE is avoided. No local high surface pressure anywhere on the flange. The high surface contact increases impermeability.

Straining screws

Optimum elongation is achieved by calculation of the tension forces and assamblage with torque wrench as well as elasticity, even under thermal load.

Peko-Schall (PFS) Flex joints

We recommend the flex joint, **Peko-Schall**, for installation in ducts with sound of achieving insulation. Peko-Schall flex joint are capable to achieve sound pressure reductions of up to 40 dB (A) depending on frequency due to the joint's special construction.

Structure borne noise is not transmitted which is valid for all fabric expansion joints.

Peko-Chimney-connect (PCC)

CREON flex joints for stack building and stack connections.

CREON-Chimneyconnect is resistant to chemical aggressions and offers thereby optimum protection for concrete shafts, consoles, refractory and steel in modern stacks.

Construction of the cross joints of inner linings is comparable with the sulforesist.

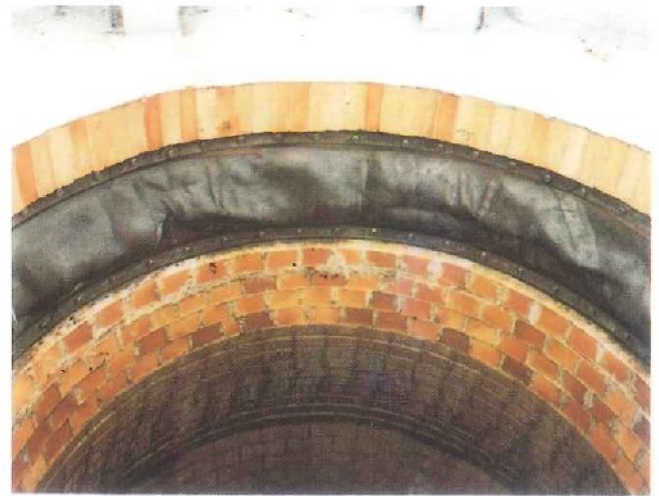

Connection with the acid-resistant inner liner and cross joints can be executed in various ways.

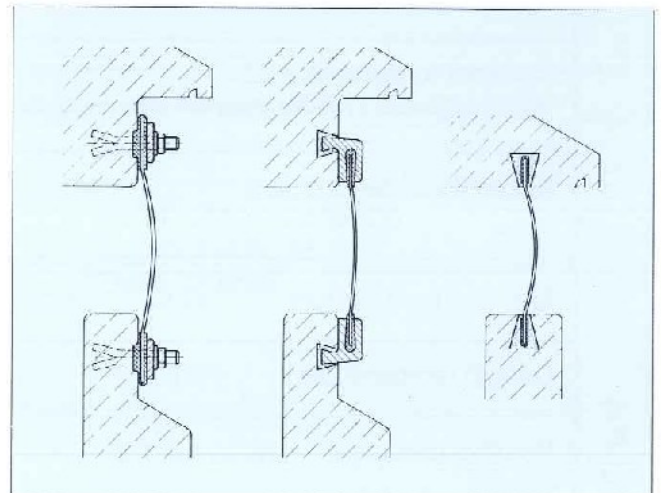

Peko-Brandschutz (PBS)

CREON has available flexible joints for wall and ceiling ducting for fire protection.

The duct passage through wall or ceiling is available as well.

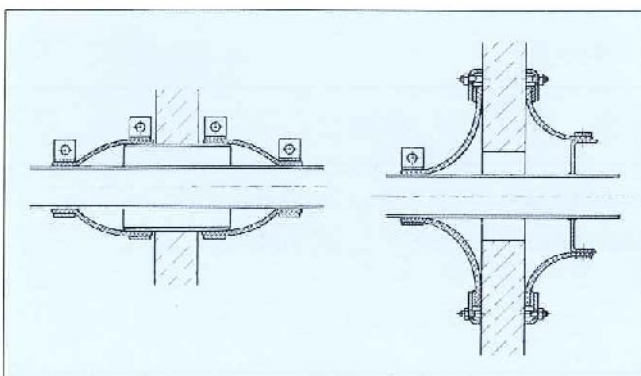

Technical Questionnaire for Fabric Expansion Joints

Company address		Telephone		
		Telex		
		Telefax		
Project engineer		Department		
Inquiry/Order No.		Project	Identification	
Date of inquiry		Desired date of delivery		
Design criteria (ref. t. P. 4)	Plant component	<input type="checkbox"/> plant under construction <input type="checkbox"/> existing plant Location <input type="checkbox"/> inside building <input type="checkbox"/> outside		
	Ambient temperature °C other ambient influences	Layout of piping	<input type="checkbox"/> horizontal <input type="checkbox"/> vertical <input type="checkbox"/> de-/inclined	
	Media (brief description)	Medium condition <input type="checkbox"/> dry <input type="checkbox"/> wet %		
	Medium temperature	t (°C)	normal	peak
	Design temperature	(°C)		
	Positive pressure	(mbar)	normal	peak
	Negative pressure	(mbar)	normal	peak
	Design pressure (mbar)			
	Velocity of flow (m/sec)		Volume of flow (Nm ³ /h)	
	Direction of flow	<input type="checkbox"/> upward	<input type="checkbox"/> downward	<input type="checkbox"/> de-/inclined (angle)
	Particle content	<input type="checkbox"/> no	<input type="checkbox"/> yes	, particle load (mg/Nm ³)
	Dew point	<input type="checkbox"/> no	<input type="checkbox"/> yes	times per °C
	Impermeability	<input type="checkbox"/> non	<input type="checkbox"/> gas tight	<input type="checkbox"/> other
	Axial compression	mm	Axial tension	mm
Lateral movement X	mm	Lateral movement Y	mm	
Vibration	Frequency (Hz)			
Range of stress	(amplitude) (mm)			

Construction form (ref. t. P.5)	Construction form <input type="checkbox"/> B1 <input type="checkbox"/> B2 <input type="checkbox"/> B3 <input type="checkbox"/> B4 <input type="checkbox"/> B5 <input type="checkbox"/> other		
Constructions	<input type="checkbox"/> round <input type="checkbox"/> oval <input type="checkbox"/> rectangular <input type="checkbox"/> conical <input type="checkbox"/> endless <input type="checkbox"/> with prepared joint <input type="checkbox"/> punched <input type="checkbox"/> not punched <input type="checkbox"/> unit ready for installation		
Number of Pieces	<input type="checkbox"/> Expansion joints <input type="checkbox"/> Installation material <input type="checkbox"/> Counter flange <input type="checkbox"/> Clamp straps <input type="checkbox"/> Duct flanges <input type="checkbox"/> Installation <input type="checkbox"/> Gasket <input type="checkbox"/> Pre-insulation <input type="checkbox"/> Baffle		
	Duct/Pipe internal diam. (mm)	Wall thickness (mm)	
	Duct flange (mm) Height a Thickness b	Distance between flanges (mm)	
Measurements	Counter flanges (mm)	Outer Inner Thickness	Bolt circle/bolt spacing Number of bore5 Diam. of bore
	Expansion joint (mm)	Inside diam. Installation length Construction length	

Sketch for special cases (see also pages 10-14)

Manufacture and delivery program

Expansion joints

Expansion joints in:
Asbestos free fabrics
Elastomers
Rubber
PVC
Complete units
Temperature resistant materials

Seals

Special seals temperature resistant to 1400 ° C
Elastomere seals
Punched flat seals in:
— Butyl
— Neoprene
— PVC
— EPDM
— Glas fabric
— PTFE with rubber core

Other materials on request.

Steel constructions

Manufacture of all steelparts
associated with expansion joints
— Flanges
— Baffle plates
— Complete units

Clamping straps

Manufacture of heavy duty clamping straps in:
— Zinc plated St 37 steel
— Stainless steel V2A

Services

— Installation of expansion joints.
— Compilation of expansion joint registers.
(please ask for brochure)

CREON

vous fournit aussi:
also provides you:

Compensateurs en caoutchouc
Rubber expansion joints



Flexibles métalliques
Flexible metal hoses

Compensateurs en tissu
Fabric expansion joints



Registres pour gaz de fumées
Flue gas valves

Flexibles composites
Flexible composite hoses





CREON

Koeweidestraat 31
Industriezone C
B-1785 Merhtem
Belgium

Tel. +32 (0)52 37 41 11 - Fax +32 (0)52 37 17 76

www.creon.be

flex@creon.be